



Reliable Water Solutions

# WATER DISPENSERS

## Catalogue 2026

---

**ELKAY**  **COSMETAL** **INTRIX** 



# CONTENTS

---

**Elkay** 01

---

**Cosmetal** 07

---

**Intrix** 13

---

**Pakai** 15

---



## ABOUT ELKAY

Elkay has been making innovative products and delivering exceptional customer care for almost a century. Elkay expanded its commercial offerings more than four decades ago, and today delivers faucets, foodservice fixtures, water coolers, drinking fountains and award-winning ezH2O® bottle filling stations, in addition to world-class stainless steel and quartz sinks.



## FEATURE & BENEFITS

Here are just a few of the many benefits our products offer :



### HYGIENIC FEATURES

Hands-free water supply options, electric sensor activation, foot pedals or knee operation panel.



### SUSTAINABLE DESIGN

Eco-friendly drinking solutions are made from recycled and recyclable materials.



### FILTERED SOLUTIONS

Filtered bottle filling stations and fountains provide cleaner, healthier drinking water.



### ADA COMPLIANT

Compliant drinking solutions make water accessible.

\*ADA compliant when properly installed.



### GREEN OPERATION

Selected drinking solutions reduce energy consumption and plastic waste, helping hotels and resorts operate more sustainably.



### VANDAL RESISTANT

Temper-resistant features withstand heavy use and defend against abuse.

## ezH2O IN-WALL BOTTLE FILLING STATION

The ezH2O can be installed alone or along with architectural fountains. Flush with wall for a seamless look makes the models ideal for office buildings or indoor recreational facilities. Product available to pair along with architectural units or with a remote chiller. Available in filtered/non-filtered, refrigerated or non-refrigerated.



LZWSM82K



LZWSMDJOK

## ezH2O BOTTLE FILLING STATION

ezH2O Bottle Filling Station units have great features to provide convenient, sustainable and healthy hydration.



### FILTER STATUS LIGHT

LED filter status indicator show when it is time to change the filter; Fillsafe recognition automatically senses new filter and turns light back to green.



### HANDS-FREE OPERATION

Touchless sensor activation designed for ease of use.



### ANTIMICROBIAL PROTECTION

Silver ion antimicrobial protection on key plastic components to inhibit the growth of mold and mildew.



LZS8WSS2K  
EZS8WSS2K

### BOTTLES SAVED

Green Ticker™ adds up how many 20 oz plastic bottles have been saved from waste.



### FLEXIBLE MOUTH GUARD

Flexi-Guard bubbler provides a flexible mouth guard to protect against injury and microorganisms.



### FILTERED

Visual filter monitor with LED filter status indicator for when filter change is necessary.



### FILTERED WATER

NSF-certified filter reduces lead and other harmful contaminants. Filter status lights let you know when easy filter changes are needed.



### STAINLESS STEEL GRATE

Stainless steel grate provides a bottle rest platform; grate is removable for easy cleaning of the basin.



### IMPROVED ACCESS

A wall projection of just 12" improves access for quick bottle fills.



LZ8WSSM2CX

### REFRESHING & REFRIGERATED

Bottle filling station delivers chilled, refrigerated water on demand.



### HANDS-FREE ACTIVATION

Touchless, sensor-activated bottle filler is designed for hygienic hydration and easy hands-free use.



### REPLACEMENT READY

Rough-in replacement is compatible with EZ and EMAB Elkay models.



## ezH2O SURFACE MOUNT WATER DISPENSER

Can be used in locations with limited wall depth or in conjunction with a fountain or remote chiller. Available with electric display and now available in a mechanically activated version with battery-powered green counter and visual filter monitor. Can be used in conjunction with a fountain or a remote chiller.



LZWSSMJO

Ambient Water



EZWSSMJO

Chilled Water

## ezH2O LIV PRO

In-Wall Commercial Filtered Water Dispenser.



**BUILT-IN DESIGN**  
Install a different water dispenser in convenient areas of your home, inside and outside the kitchen. Designed for new construction remodels.

**SENSOR ACTIVATED**  
Hands-free filling with automatic timed shut off to prevent accidental spills and messes.

**FILTERED WATER**  
NSF-Certified filter reduces lead and other harmful contaminants. Filter status lights indicate when filter needs changing so you always know you are serving filtered water.

**BOTTLES SAVED**  
Backlit LED Green Ticker counts the number of disposable single-use plastic bottles served without the plastic bottle waste.

**CHICK STYLING**  
Glass and brushed stainless steel design looks great in any room; interactive light brightens when dispensing water.

**EASY INSTALLATION**  
Fits within the width and depth of two standard wall studs, near water and electrical. It includes a drip tray with optional drain connection; can connect into existing water line.

## AMBIENT WATER WITH CHILLED WATER OPTION

Chilling capacity of 1.5 GPH of 50°F drinking water



**LBWD2C00BKC**  
18"W x 28"H x 5-1/4"D  
(1-1/4" protrusion from wall surface)  
Non-refrigerated  
Rated Watts: 25

**EFBLIVSC**  
ezH2O Liv® Filter Box Kit



**LBWD2C00WHC**  
18"W x 28"H x 5-1/4"D  
(1-1/4" protrusion from wall surface)  
Non-refrigerated  
Rated Watts: 25

**EFBLIVSC**  
ezH2O Liv® Filter Box Kit



**LBWD2C00BKC**  
18"W x 20-1/2"H x 5-1/4"D  
(1-1/4" protrusion from wall surface)  
Chilling Option: 1.5 GPH  
Rated Watts: 25



**LBWD2C00WHC**  
18"W x 20-1/2"H x 5-1/4"D  
(1-1/4" protrusion from wall surface)  
Chilling Option: 1.5 GPH  
Rated Watts: 25

## LIV ez

Built-In Water Dispenser



**Midnight**

LBWDM0BKBC



**Steel Gray**

LBWDM0SSBC



**Aspen White**

LBWDM0WHBC

### **SUSTAINABLE.**

The backlit Green Ticker keeps count of all the single-use plastic bottles you aren't wasting.

### **BATTERY POWERED.**

No unsightly cords and no electrician needed, just three AA batteries that last around a year.

### **READY. SET. CERTIFIED.**

Filter is tested and certified to NSF/ANSI 42, 53, and 401 to reduce PFOA/PFO5, lead microplastics, cysts, chlorine, and taste and odor.

### **FILTERED WATER. ALWAYS.**

LED light indicates when effortless filter changes are needed.

### **INTELLIGENTLY ENGINEERED.**

This sleek water dispenser features premium glass and durable stainless steel, complementing any decor.

### **EZ TO INSTALL, EZ TO MAINTAIN**

The lightweight glass front is easy to clean and remove for filter and battery access. Only one water line is needed for simple DIY or professional installation.



LBWDM0BKBC  
Midnight



LBWDM0SSBC  
Steel Gray



LBWDM0WHBC  
Aspen White

## OUTDOOR BOTTLE FILLING STATION

Perfect for parks, golf courses, or pool areas. The outdoor bottle filling stations provide hydration on the go. Made of durable cold rolled steel and immersed in an E-Coat for the ultimate corrosion protection. Flexible configurability to meet any application with freeze resistant models available.

*Available in 12 color options with textured finishes.*



LK4430BF1UBLU



LK4400DBEVG



LK4420BF1UGRY



LK4420BF1LBLU



Black



Blue



Evergreen



Gray

## AVADO BEVERAGE FAUCET

The Avado filtered beverage faucet provides cold, filtered water, while saving time and money by eliminating the need for disposable plastic water bottles. The long-life filter reduces lead and other contaminants for peace of mind and great-tasting water.

### 3 Stunning Colors



Chrome (CR)



Lustrous Steel (LS)



Matte Black (MB)

### GOOSENECK SPOUT

High arc design makes it easy to fill larger items such as pots, coffee carafes and pet dishes with crisp cold water.



### INTEGRATED FILTRATION

Healthier hydration is within reach with a filtered beverage faucet in the kitchen, bar area or mudroom.



### SPACE-SAVING FILTER INSTALLATION

Filter mounts to sink cabinet wall to keep sink area free of clutter and attractive.



LKAV71FCR

### ALL-IN-ONE SYSTEM

Nothing extra to buy - the filter and everything you need for installation is included.



### COLD WATER ONLY

Beverage faucet hooks into cold water line. Elkay has an array of stylish kitchen faucets to coordinate with the beverage faucet.



### ONE FAUCET HOLE

Beverage faucet is designed to be installed using a secondary faucet hole next to your main faucet.



## WATERSENTRY FILTER 51300C

Replacement Filter for Elkay ezH2O and Halsey Taylor Bottle Filling Stations. Tested and certified to NSF/ANSI 42 and 53, our 3,000-gallon filter reduces chlorine taste and odor, as well as contaminants such as lead, cysts, and particulates. The result is healthier, better-tasting drinking water.



**LEAD**



**SEDIMENT**



**PARTICULATES**



**CHLORINE TASTE AND ODOR**



**CYSTS**



- NSF 372 (Lead free)
- NSF 42
- NSF 53
- NSF 401
- Filter Qualified
- Well V1
- Well V2
- Standard



# HI CLASS PREMIUM

## CERTIFICATIONS



### High-tech Control Panel

Black tempered glass front with anti-fingerprint stainless steel insert, two-colour display size 128x64 and touchscreen control panel.



### Adjustable Dispensing

Dispensing zone with adjustable height: from minimum 22 cm – suitable for withdrawing water with a cup or glass – to maximum 27 cm for use with bottles. Hot water dispensing is protected by a safety device.



### Temperature

Ultra-precise electronic thermostats for guaranteeing accurate adjustment and reading of the hot/cold water temperature.



### Operating Parameters Programming (IT/EN/DE/FR)

The operating parameters must be set by qualified personnel and protected by a password.



### Real-time Parameter Control

The water dispenser allows for viewing in real time the following operating parameters:

- Temperature of the hot/cold water
- Capacity and duration of the filtration system and relative UV lamp
- CO2 cylinder level
- Date of the next sanitisation intervention.



### Self-diagnosis System

The display promptly signals any anomalies or malfunctions, such as lack of mains water, clogged filter, etc., so as to prevent seizures.



### Energy Saving

The energy saving function can be inserted manually when required, or programmed on a weekly basis.



### Filtration

An extensive range of filters is available to improve the water's flavour and aroma, for combating limescale and for preventing bacteria from entering the water mains.



### Drip Tray with Drain

The drip tray, with a capacity of max. 400 ml, allows for channelling excess water to a drain or, alternatively, into an appropriate optional tank fitted with an overflow sensor.



### Matching Cabinet

Optional matching cabinet with integrated cup holder for 100 cups. Waste kit included.

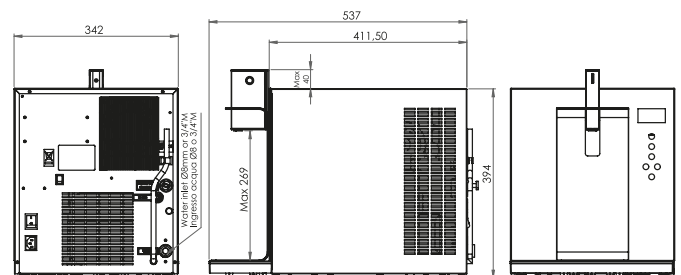

## Gamma Range

					Assorbimento Rated input
<b>HI CLASS TOP 45 IB AC</b>	■	■			230 W
<b>HI CLASS TOP 45 IB ACWG</b>	■	■		■	400 W
<b>HI CLASS TOP 45 IB ACHWG</b>	■	■	■	■	1600 W

# HI CLASS PREMIUM

## Technical Features / Specification

<b>Dimension</b>	34cm (W) x 54cm (D) x 40cm (H)
<b>Cooling Performance</b>	45 lt/h; 9 lt in continuously
<b>Dispensed Cold Water Temperature</b>	3-10°C with 20°C incoming water and 25°C room temperature
<b>Heating Performance</b>	13 lt/h; 1,2 lt in continuously
<b>Dispensed Hot Water Temperature</b>	98°C
<b>Dispensing</b>	40sec./lt for natural water, 35sec./lt for sparkling (with 3 bar of incoming water pressure)
<b>Condensation</b>	Ventilated blowing
<b>Thermostat</b>	Electronic
<b>Compressor</b>	1/10 HP
<b>Ice Bank</b>	4lt capacity, 2kg of ice
<b>Carbonator Pump</b>	Rotary vane, 100 lt/h - 9 bar (for WG models)
<b>Carbonator (Cold Carbonation)</b>	1 lt capacity (for WG models)
<b>Hot Tank</b>	1,5 lt capacity, rated input 1200 W
<b>Inlets / Outlets</b>	Water inlet Ø 8 mm, CO2 inlet Ø 6 mm (for WG models)
<b>Safety</b>	Inlet safety valve
<b>Water and Co2 Pressure Reducers</b>	Not included
<b>Filters</b>	Not included, to be externally mounted in-line

## Filtration / Purifier

## Cod.

<b>F-SMALL+</b>	Customized chlorine filter/purifier with bypass head.	099207
<b>F-CAL</b>	Customized chlorine purifier filter, bacteriostatic, descaler with shut off head.	099109
<b>F-MICRO</b>	Customized anti-bacterial micro-filter, with shut off head.	099112
<b>F-SOFT</b>	Ion exchange resin filter purifier for hardness reduction with shut off head.	099200
<b>FC</b>	Multilayer + Carbon Block filters.	090052
<b>F</b>	4C Chlorine filter/purifier with head and shut off valve.	099033
<b>F-UV</b>	F + UV 12W sterilizer.	090034

# H2OMY TOP

## CERTIFICATIONS



### Unlimited Water

Smaller than a crate of 6 water bottles, it dispenses up to 15 litres per hour of cold water - between 3° and 10° C - still or sparkling, and 8 litres per hour of hot water, from your tap, straight into the glass.



### Cutting Edge Technology

Ice-bank cooling and cold carbonation technology offers optimum performance within a compact space.



### Simplicity and Flexibility

This simple and compact product can be further customized to satisfy individual requirements.



### Matching Cabinet

Optional matching cabinet with integrated cup holder for 100 cups.



### Counter-top Solution

H2OMY TOP, compact in terms of size and shape, optimises the efficiency of home or office water management while bringing a touch of style and technology to the area in which it is installed.



### Hygiene

The dispensing area is protected from environmental pollution while the controls are situated at a safe distance from the dispensing point.



### Safety

The safety valve prevents loss of water due to potential failures occurring inside the machine.



### Functionality

The drip tray with 400 ml capacity can be removed to facilitate filling of all types of disposable and reusable cups, tall bottles or jugs.

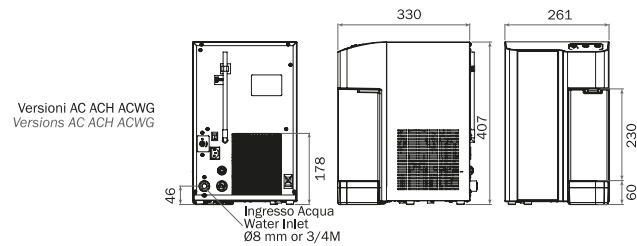

Versioni CHWG  
Version CHWG

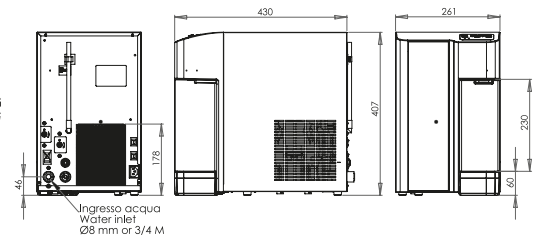

## Gamma Range

					Assorbimento Rated input
<b>H2OMY TOP 15 IB AC</b>	■	■			190 W
<b>H2OMY TOP 15 IB ACH</b>	■	■	■		1390 W
<b>H2OMY TOP 15 IB ACWG</b>	■	■		■	260 W
<b>H2OMY TOP 15 IB CHWG</b>		■	■	■	1460 W

# H2OMY TOP

## Technical Features / Specification

<b>Dimension</b>	See drawings
<b>Cooling Performance</b>	15 lt/h; 3 lt continuously
<b>Dispensed Cold Water Temperature</b>	3-10°C with 20°C incoming water and 25°C room temperature
<b>Heating Performance</b>	13 lt/h; 0,8 lt continuously
<b>Dispensed Hot Water Temperature</b>	95°C
<b>Dispensing</b>	40 sec./lt for natural water; 35 sec./lt for sparkling (with 3 bar of incoming water pressure)
<b>Condensation</b>	Ventilated blowing
<b>Thermostat</b>	Mechanical
<b>Compressor</b>	1/12 HP
<b>Ice Bank</b>	2lt capacity, 2kg of ice
<b>Carbonator Pump</b>	Membrane pump 80 lt/h - 8 bar (for WG models)
<b>Carbonator (Cold Carbonation)</b>	0,5 lt capacity (for WG models)
<b>Hot Tank</b>	1 lt capacity, rated input 1200 W
<b>Inlets / Outlets</b>	Water inlet Ø 8 mm, CO2 inlet Ø 6 mm (for WG models)
<b>Safety</b>	Inlet safety valve
<b>Water and Co2 Pressure Reducers</b>	Not included
<b>Filters</b>	Not included, to be externally mounted in-line

## Filtration / Purifier

Cod.

<b>F-SMALL+</b>	Customized chlorine filter/purifier with bypass head.	099207
<b>F-CAL</b>	Customized chlorine purifier filter, bacteriostatic, descaler with shut off head.	099109
<b>F-MICRO</b>	Customized anti-bacterial micro-filter, with shut off head.	099112
<b>F-SOFT</b>	Ion exchange resin filter purifier for hardness reduction with shut off head.	099200
<b>FC</b>	Multilayer + Carbon Block filters.	090052

# PRO-STREAM IN 55 OT

## CERTIFICATIONS



**Tap**  
Chrome-plated, thermally isolated body and touch control panel equipped with safety device for safe dispensing of extra-hot water.



**Installation**  
An appropriate template facilitates installation operations. The tap can be mounted near the sink or on any supporting top together with the drip tray and drain.



**Adjustable Dispensing**  
Equipped with electronic temperature control and anti-boiling function, Pro-stream instantly dispenses water at 98°C and fills up to 215 cups/hour with extra-hot water. In addition, by adding the appropriate options, it can dispense 15 litres/hour of cold and/or sparkling water.



**Control Panel**  
The status of the lights on the control panel signals the boiler's operating phases: ready, heating and off.



**Modular Construction**  
If the cold and/or sparkling water function is present, a specific unit for producing cold water is added to complete the boiler.



**Technology**  
Hot water open tank. Any steam generated is channelled through the drain conduit. Boiling point pre-settable according to altitude.



**Energy Saving**  
The energy saving function activates automatically after two hours of non-use, by lowering the temperature of the water inside the tank down to 65°C; after a further one hour of non-use, the boiler switches off automatically.



**Filtration**  
Optional water softening filter for protecting the system against limescale build-up.



**Limescale Removal**  
Designed for rapidly running a complete wash cycle inside the machine, thanks to the relevant function that fully empties the tank.



### Gamma Range

				Assorbimento Rated input
<b>PRO-STREAM HOT</b>	■			2600 W
<b>PRO-STREAM HOT&amp;COLD</b>	■	■		2600 W 155 W
<b>PRO-STREAM HOT, COLD AND SPARKLING</b>	■	■	■	2600 W 210 W

### Drip trays

#### VR-G7

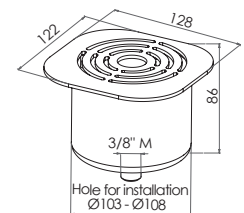

Size of G7 Faucet

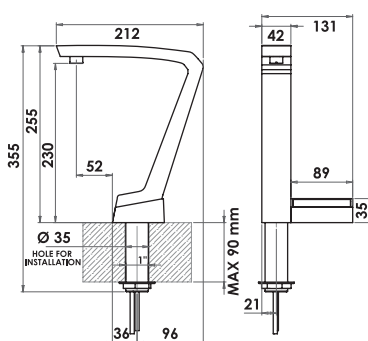

Pro-Stream Hot

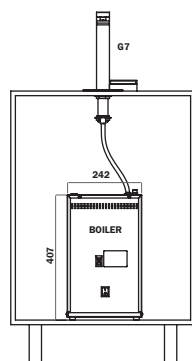

Pro-Stream Hot & Cold

G7 + Boiler + H20MY IN 15 IB C + Box Solenoid C

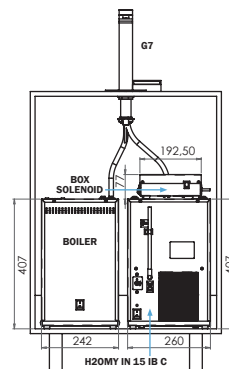

Pro-Stream hot, Cold & Sparkling

G7 + Boiler + H20MY IN 15 IB CWG + Box Solenoid CWG

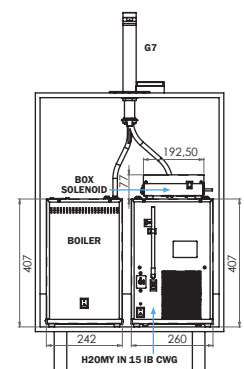

# PRO-STREAM IN 55 OT

## TECHNICAL FEATURES

	BOILER	H2OMY IN C	H2OMY IN CWG
<b>Dimensioni</b> <i>Dimensions</i>	24,2 L x 31,5 P x 40,7 H cm 24,2 W x 31,5 D x 40,7 H cm	26 L x 23,5 P x 40,7 H cm 26 W x 23,5 D x 40,7 H cm	26 L x 30 P x 40,7 H cm 26 W x 30 D x 40,7 H cm
<b>Assorbimento</b> <i>Rated Input</i>	2600 W 2600 W	155 W 155 W	210 W 210 W
<b>Prestazione</b> <i>Performance</i>	55 lt/h 55 lt/h	15 lt/h; 7 e 3 lt in continuo 15 lt/h; 7 and 3 lt continuously	
<b>Erogazione</b> <i>Dispensing</i>	30 sec. / lt di acqua calda 30 sec. / lt for hot water	40 sec. / lt liscia (con 3 bar di pressione in ingresso) 40 sec. / lt for natural water (with 3 bar of incoming water pressure)	40 sec. / lt liscia; 35 sec. / lt gassata (con 3 bar di pressione in ingresso) 40 sec. / lt for natural water; 35 sec. / lt for sparkling (with 3 bar of incoming water pressure)
<b>Condensazione</b> <i>Condensation</i>		Ventilata Ventilated	Ventilata Ventilated
<b>Termostato</b> <i>Thermostat</i>	Elettronico, preimpostato a 98 °C Electronic, preset at 98 °C	Meccanico Mechanical	Meccanico Mechanical
<b>Compressore</b> <i>Compressor</i>		1/12 HP 1/12 HP	1/12 HP 1/12 HP
<b>Elemento riscaldante</b> <i>Heating element</i>	2500 W 2500 W		
<b>Banco di ghiaccio</b> <i>Ice bank</i>		Capacità 2 lt, 1 Kg di ghiaccio 2 lt capacity, 1 Kg of ice	
<b>Serbatoio caldo</b> <i>Hot tank</i>	7 lt 7 lt		
<b>Pompa di carbonazione</b> <i>Carbonator pump</i>			A membrane 80 lt/h - 8 bar (per le versioni WG) Membrane Pump, 80 lt/h - 8 bar (for WG models)
<b>Carbonatore (gasatura a freddo)</b> <i>Carbonator (cold carbonation)</i>			Capacità 0,5 lt (per le versioni WG) 0,5 lt capacity (for WG models)
<b>Ingressi/uscite</b> <i>Inlets/outlets</i>	Ingresso acqua Ø 8 mm, uscite acqua Ø 6 mm Water inlet Ø 8 mm, water outlets Ø 6 mm		Ingresso acqua Ø 8 mm, uscite acqua Ø 6 mm, ingresso CO2 Ø 6 mm (per le versioni WG) Water inlet Ø 8 mm, water outlets Ø 6 mm, CO2 inlet Ø 6 mm (for WG models)
<b>Riduttori di pressione per acqua e Co2</b> <i>Water and Co2 pressure reducers</i>	Non inclusi Not included		
<b>Sicurezza</b> <i>Safety</i>	Elettrovalvola in ingresso Inlet safety valve		
<b>Filtro</b> <i>Filter</i>	Non incluso, da montare esternamente in linea Not included, to be externally mounted in-line		
<b>Filtro suggerito</b> <i>Suggested filter</i>	F-SOFT F-SOFT	F-SMALL+, F-CAL, F-MICRO, FC F-SMALL+, F-CAL, F-MICRO, FC	

## FILTRATION

		Cod.
<b>F-SMALL+</b>	Filtro personalizzato dechloratore urificatore con testata bypass Customized chlorine filter/purifier with bypass head	099207
<b>F-CAL</b>	Filtro personalizzato dechloratore urificatore batteriostatico anti-calcare, con testata shut off Customized chlorine purifier filter, bacteriostatic, descaler with shut off head	099109
<b>F-MICRO</b>	Micro-filtro personalizzato antibatterico, con testata shut off Customized anti-bacterial micro-filter, with shut off head	099112
<b>F-SOFT</b>	Filtro purificatore con resina a scambio ionico per la riduzione della durezza con testata shut off Ion exchange resin filter purifier for hardness reduction with shut off head	099200
<b>FC</b>	Filtro multistrato + carboni attivi Multilayer + Carbon Block filters	099034

## INTRIX ONE HOTEL Malaysia's 1st Drinkable Multi-Usage Tap

### World Class All-in-One Water Purification System

Effectively removes 99.99% microbes down to 0.01 micron (µm)



#### Sediment Filter

Removes soil, rust, sediment and bigger particles.



#### Activated Carbon Block

Removes cysts, unpleasant odours, chlorine, chloramine, trihalomethane, VOCs and heavy metals.



#### Nanofiltration Membrane

Removes bacteria, algae and some viruses while preserving natural minerals.



#### Eco-friendly

INTRIX filters are designed to be 95% recyclable with more than 80% wastage reduction.



- **Stylish & Space-Saving**
- **Low-Maintenance**
- **EcoSmart Technology**
- **Highly Secured & Heatproof Tap**



National Sanitation Foundation (USA) 42/53/401



Korean Halal Certification

### Water Technology vs INTRIX One Hotel

	Boiled Water	Micro-Filtration Water	Alkaline Water	Reverse Osmosis Water	INTRIX One Hotel
Contains Minerals	☑	☑	☑		☑
Eliminates Heavy Metals				☑	☑
Mild Alkaline			☑		☑
Eliminates Bacteria	☑	☑		☑	☑
Eliminates Viruses	☑			☑	☑
Eliminates Chemical Toxins	☑			☑	☑

## INTRIX HORECA FILTER

Assured Great Water for Better Food Service



### KEY FEATURES :

- **200% extra filtration lifespan** (80,000 Litres or 1 year, whichever comes first).
- **High flow rate** (6.4 Litres / mins or 12.8 Litres / mins).
- 2-stage water purification system (0.5 micron) - Sediment + Carbon
- NSF 42 & Halal certified.
- Improved taste.



Removal of microbes down to 0.01 micron ( $\mu\text{m}$ )



Ultra-high capacity filter 80,000L



Removes bacteria, algae and some viruses while preserving natural minerals

# PAKAI ENDEO

## Heavy Duty Water Dispenser



- A free-standing water dispenser designed for **heavy duty usage**.
- Comes with 3 water options:  
**Cold, ambient** and **hot** to meet all kinds of beverage/drinking needs.
- **Ultra-high capacity filter** for high traffic usage.

### PRODUCT SPECIFICATION

- Power Hot/Cold: 2000W/150W
- Tank Material: Stainless Steel 304
- Body Material: Stainless Steel 201
- Water Selection: Hot/Ambient/Chilled

Tank Capacity	<ul style="list-style-type: none"> <li>• Hot: 10L</li> <li>• Ambient: 20L</li> <li>• Chilled: 3L</li> </ul>
Dimension (cm)	<ul style="list-style-type: none"> <li>• Length: 48.5 (56cm with water tray)</li> <li>• Depth: 42.5</li> <li>• Height: 132</li> </ul>
Output	<ul style="list-style-type: none"> <li>• Hot at 85°C-90°C: 30L/hr (approx. 240 cups/hr)</li> <li>• Cold at 4°C-12°C: 10L/hr (approx. 60 cups/hr)</li> </ul>



**THE BEST SOLUTION  
FOR CLEAN WATER**

Quality Assurance of Assure X10:



National Sanitation  
Foundation (USA) 42/53/401



Korean Halal  
Certification

# PAKAI BERMIN SINGLE LEVER FILTERED TAP - DT22980C

With INTRIX X10 Filter & Cap | Chromed Finish

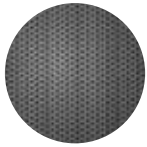

### Activated Carbon Block

Removes cysts, unpleasant odours, chlorine, chloramine, trihalomethane, VOCs and heavy metals.



### Eco-friendly

INTRIX filters are designed to be 95% recyclable with more than 80% wastage reduction.



### Sediment Filter

Removes soil, rust, sediment and bigger particles.



### Nanofiltration Membrane

Removes bacteria, algae and some viruses while preserving natural minerals.



- **Stylish & Space-Saving**
- **Low-Maintenance**
- **EcoSmart Technology**
- **Highly Secured & Heatproof Tap**



National Sanitation Foundation (USA) 42/53/401



Korean Halal Certification

	Contains Minerals	Eliminates Heavy Metals	Mild Alkaline	Eliminates Bacteria	Eliminates Viruses	Eliminates Chemical Toxins
<b>Boiled Water</b>	✓			✓	✓	✓
<b>Micro-Filtration Water</b>	✓			✓		
<b>Alkaline Water</b>	✓		✓			
<b>Reverse Osmosis Water</b>		✓		✓	✓	✓

# PAKAI PREMIUM SIPHON BACKWASHING WATER-DRIVEN FILTER - BS-PFSQ550B

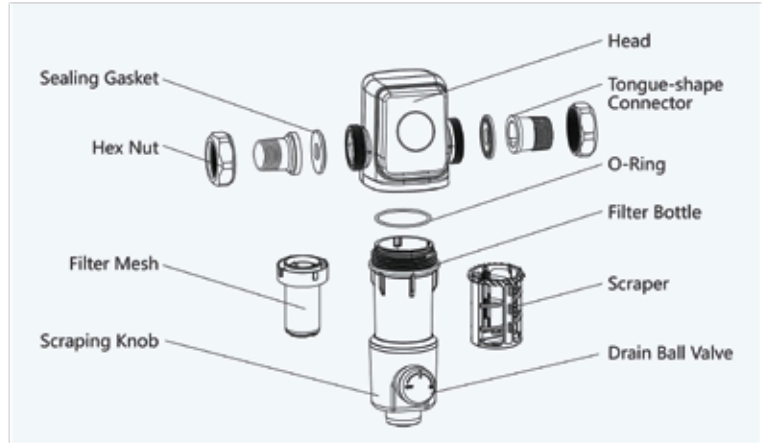

Parameter	
<b>Water Flow</b>	5 T/H (22GPM)
<b>Connector</b>	3/4" (1/2" or 1" available)
<b>Filtration Accuracy</b>	40 & 300 Micron
<b>Certifications</b>	NSF, RoHS, SGS
<b>Applicable Water Pressure</b>	0.15MPa - 1MPa (21.8Psi - 145Psi)
<b>Applicable Water Quality</b>	Municipal Tap Water
<b>Cross Weight</b>	1.38 KG
<b>Item Weight</b>	1.0 KG
<b>Applicable Environment Temperature</b>	+1 °C - +40 °C (33.8 F - 104 F)
<b>Product Dimension</b>	310 x 155 x 126 mm
<b>Included Components</b>	Wrench, Manual, Sewer Drain Connector, Sewage Drain Pipe
<b>Flushing Mode</b>	Auto
<b>Connector Material</b>	Premium H59-1 Brass
<b>Filter Mesh Material</b>	SUS 316 Stainless Steel

## PAKAI PRE-FILTER - HD-PF01



### Installation Diagram:

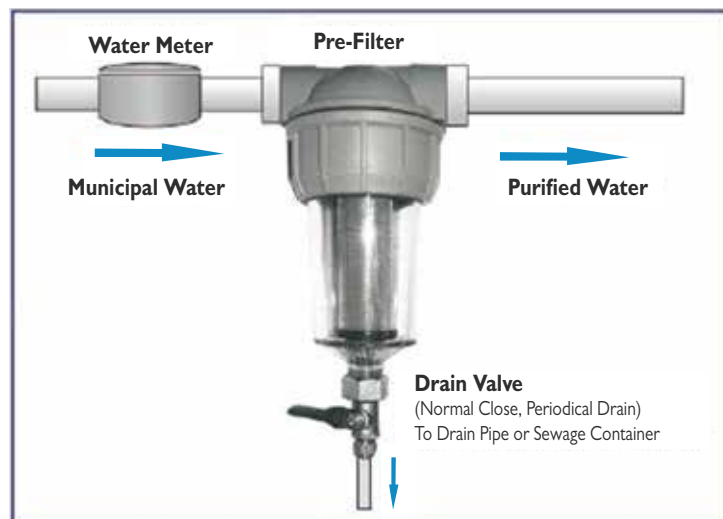

### Filtration & Function:

- Remove sand, silt, and rust particles in water.
- Solve the problem of secondary pollution in the distribution of municipal water pipeline network and turbidity of water in rural ground water.

### Siphons Cartridges for option:

Prevents “brown” or “red” water and clogged pipes, keeps pipe work clean.

- High Filtration Precision
- Excellent Performance
- Simple Structure
- Easy Operation

Parameter	
Model No	HD-PF01
Water Source	Municipal Water
Suitable Pressure	0.1 - 1 mpa
Water Flow	2000 L/H
Water Inlet	1/2 inch
Purified Water Output	1/2 inch
Drain Outfall	1/2 inch
Filtration Precision	40-90 $\mu\text{m}$
Rating Temp	5 - 40 $^{\circ}\text{C}$
Packing Dimension	215 x 115 x 100 mm

## PAKAI ULTRAVIOLET WATER STERILIZER - HD-UV12W



Diagram:

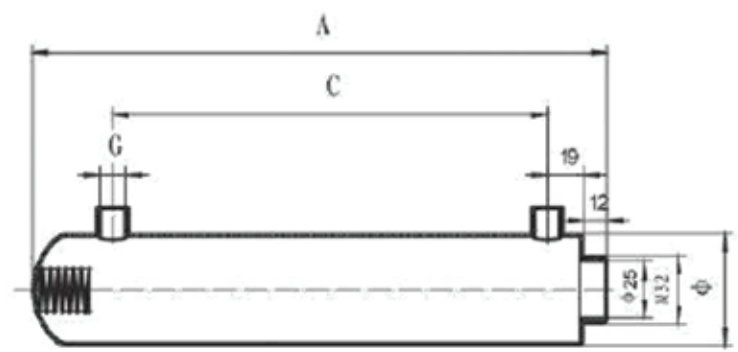

### FEATURES:

#### Improves Quality Of Home Drinking Water

The UV water sterilizer uses short-wave ultraviolet (UV) light at a 254nm wavelength to destroy the DNA of bacteria and viruses. This process effectively sterilizes the microorganisms, ensuring the water is safely disinfected without the use of chemicals

#### Water Treatment without Chemical

UV is a highly effective water treatment method known for its strong germicidal properties. A 12V UV water sterilizer can efficiently neutralize harmful microorganisms, including protozoans such as Giardia lamblia cysts and Cryptosporidium oocysts.

#### Effective & Economical

Enhancing water safety with advanced UV technology. The 1GPM UV sterilizer offers a dependable and effective solution for disinfecting potable water, wastewater, recycled water, and rainwater — continually improving through ongoing technological advancements.

#### Easy Installation

Installation is quicker and easier thanks to its compact design and simplified components. Packing Dimension: 500x750x385mm/18pcs

#### Parameter:

GPM	Specification	Dimension (mm)					Quartz Sleeve	UV Lamp	Quantity of UV Lamp
		A	C	G	Ø				
1G	12W	300	227	1/4 "	2 "	296	387	1	



Scan to download our Catalogue



Scan to chat with Our Sales Team



Scan to chat with Our  
Customer Service Team



Your Washroom Solution Partner

**PAKAI INDUSTRIES BERHAD** (196901000011)

B-LG-1, Connaught Avenue, Jalan 9,  
Taman Bukit Cheras, 56000  
Kuala Lumpur, Malaysia.

Email : sales@pakai.com  
Website : www.pakai.com  
Cheras HQ : +603 9107 4950

**SANIEURO THAI CO., LTD.**

343/25-26 Thanon Klong Lam-Jiag,  
Nuanchan, Buengkum, Bangkok,  
10230, Thailand.

Phone : +66(0) 63 919 6365  
Fax : +662 105 3400  
Email : sales.th@sanieuro.com  
Web : www.sanieuro.com/th

**SANIEURO MYANMAR CO., LTD.**

No. 12, Room 7, Parami Road,  
Chaw Dwin Gone, Ma Yan Gone,  
Township, 11061 Yangon, Myanmar.

Phone : +959 450 33 5111  
Fax : +09 267 48 1770  
Email : sales.mm@sanieuro.com  
Web : www.sanieuro.com/mm

**SANIEURO UK LTD.**

9E Insignia Point, 2 East Park Walk,  
E20 1JB London, United Kingdom.

Phone : +44 7497761226  
Email : sales@sanieuro.com

**CONG TY TNHH SANIEURO VIETNAM**

BPA Apartment - 02.10 Botanica Building  
Premier No. 108, Hong Ha, Ward 2,  
Tan Binh District, Ho Chi Minh City, Vietnam.

Phone : +84 90 9722086  
Email : sales@sanieuro.com

**NOVATEC SANITARYWARE LANKA (PVT) LTD.**

No. 9, Chilaw Road, Negombo, Sri Lanka.

Phone : +94 31 4936843 / 31 4936847  
Fax : +94 31 2223535  
Email : sales.lk@sanieuro.com  
Web : www.sanieuro.com/lk

**IDEAL KITCHEN AND BATHROOM PTE LTD.**

545 Balestier Road Singapore 329866  
Singapore

Phone : +65 8282 8228  
Email : sales@sanieuro.com  
Web : www.ideal.com.sg

Email: sales@sanieuro.com | Website: www.sanieuro.com | Tel: +603-9107 4950



Every dispenser saves thousands of plastic bottles annually.  
Together, we deliver cleaner water and a greener planet.